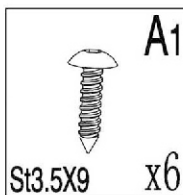
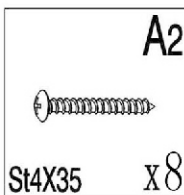
**A**

x2

**A1**

St3.5X9 x6

**A2**

St4X35 x8

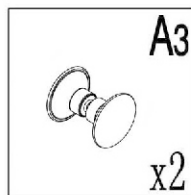
**A3**

x2

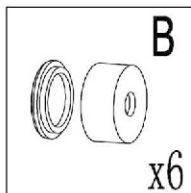
**B**

x6

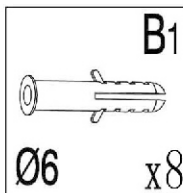
**B1**

Ø6 x8

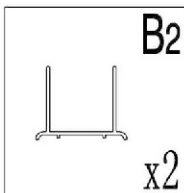
**B2**

x2

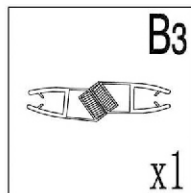
**B3**

x1

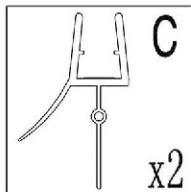
**C**

x2

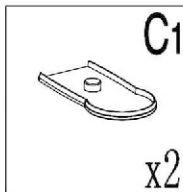
**C1**

x2

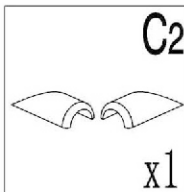
**C2**

x1

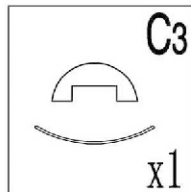
**C3**

x1

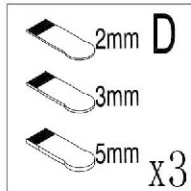
**D**

x3

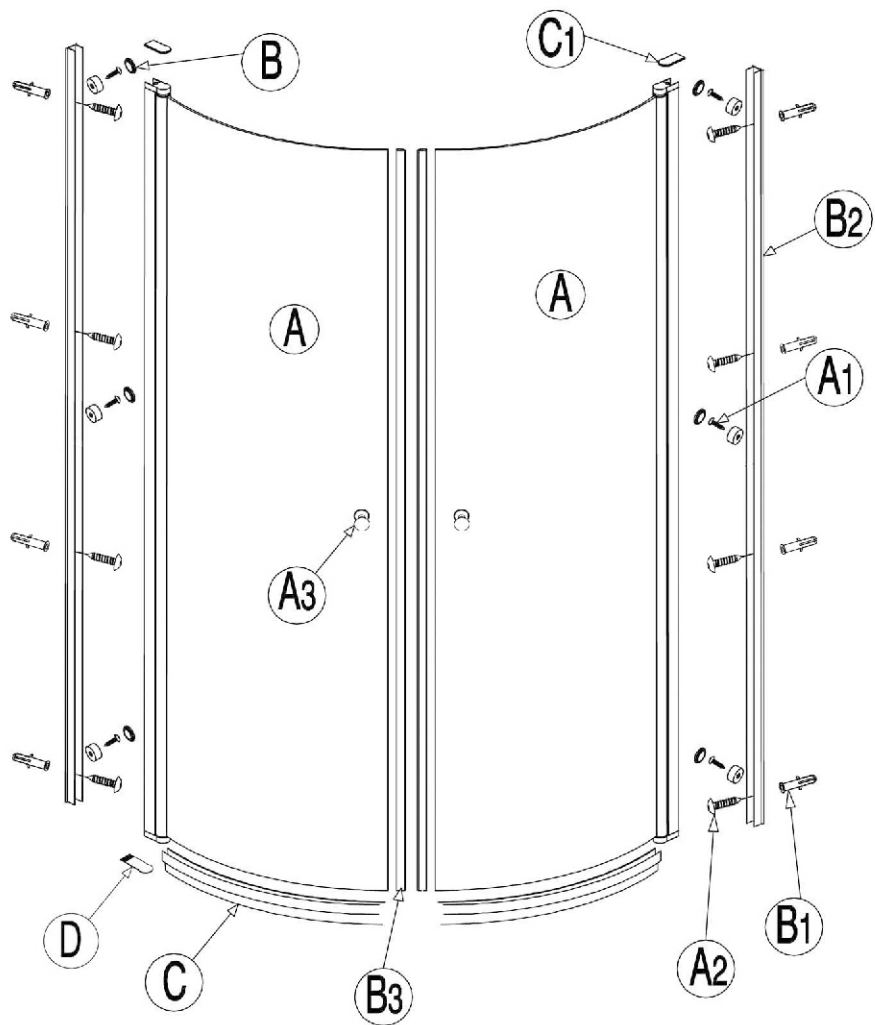

	a
800x800	783
900x900	883

Merk:

A-mål=Fra hjørne til senter av veggprofil.

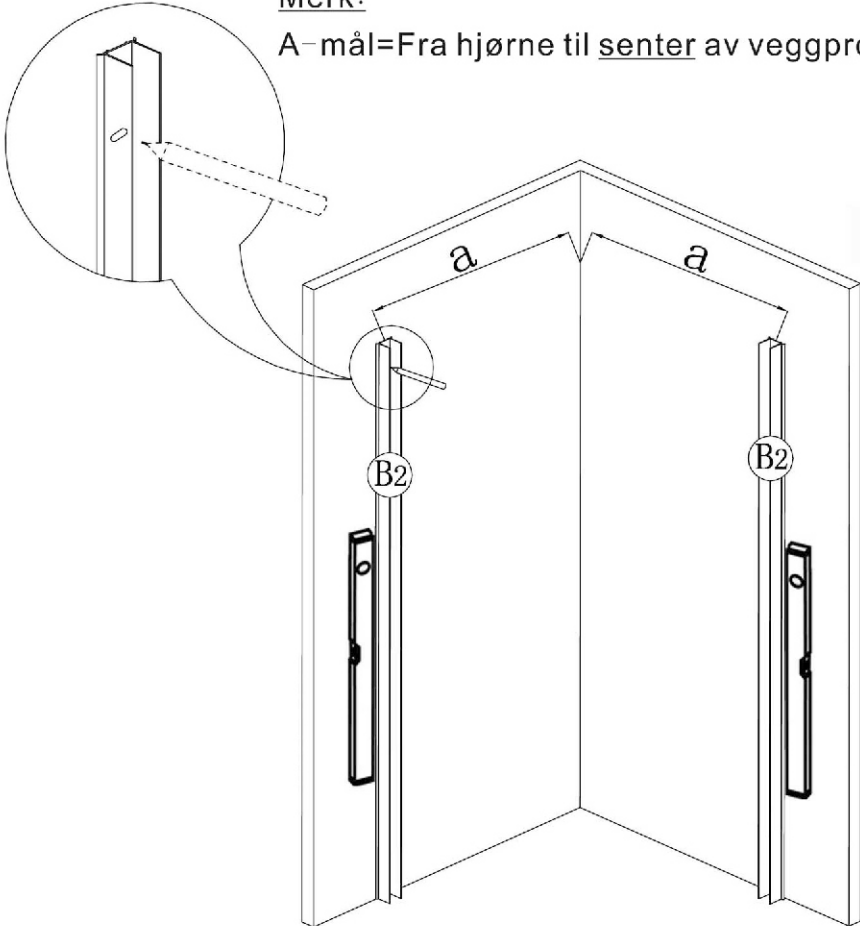

Viktig at veggprofilene er i vater.

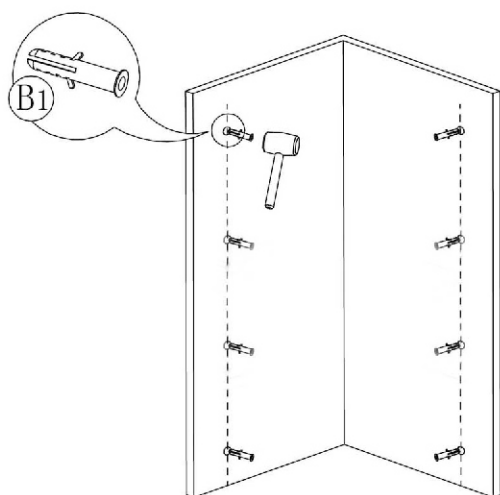
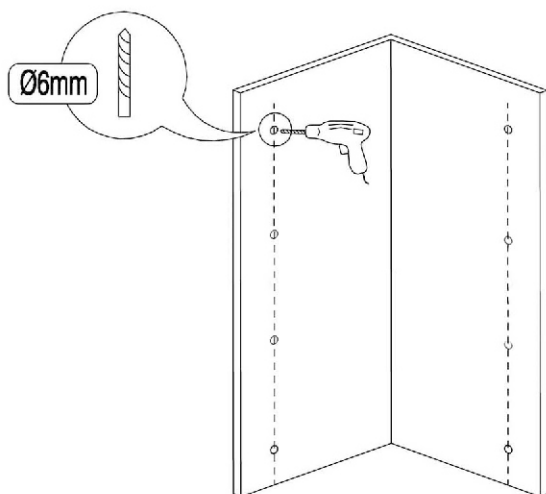

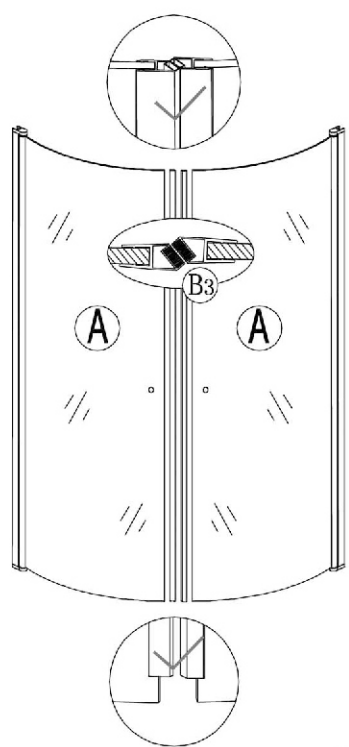
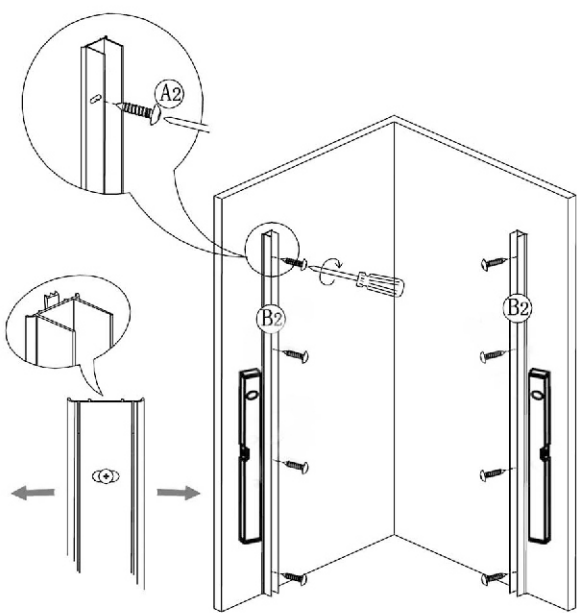

NB! Viktig at glassveggene ikke monteres oppe på vegg,
men på gulv.
Hvis veggene må
heves pga
fall, Bruk
vedlagt sjims/kil.

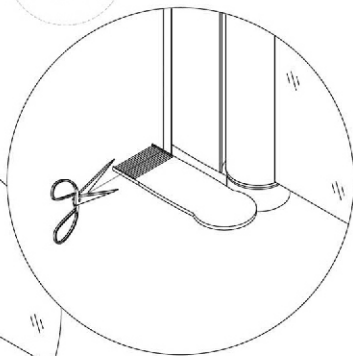
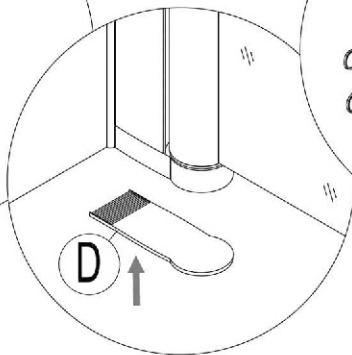
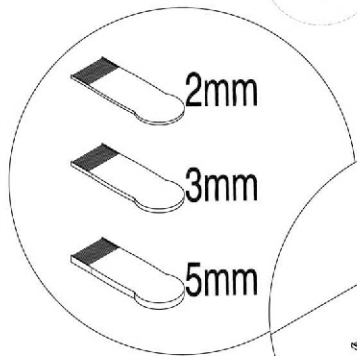
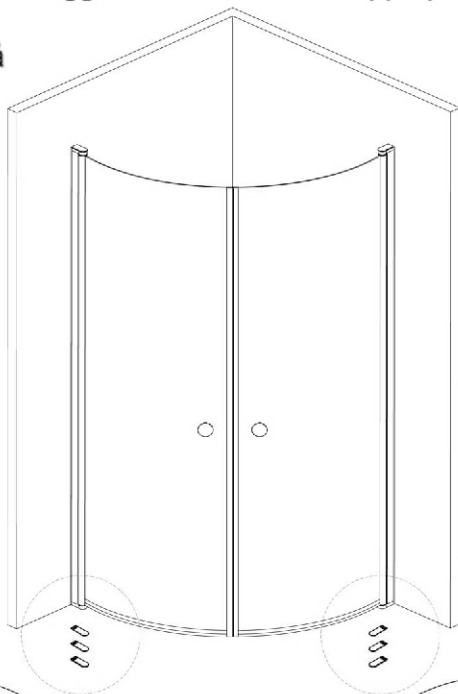

Bruk utjevningsbrikke / kil ved behov.

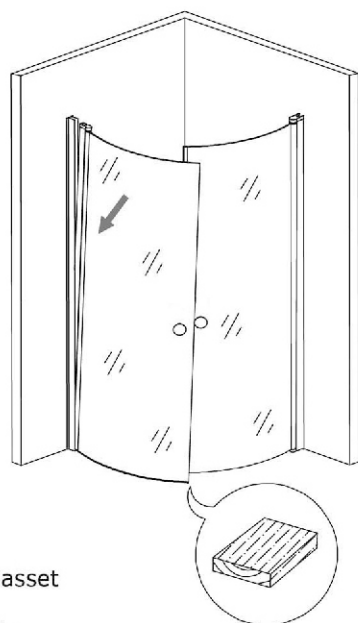
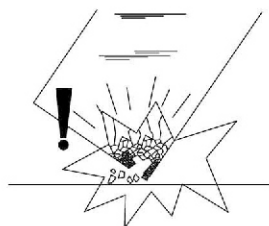
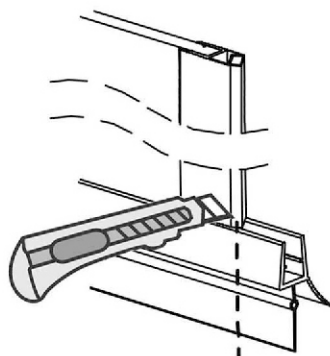
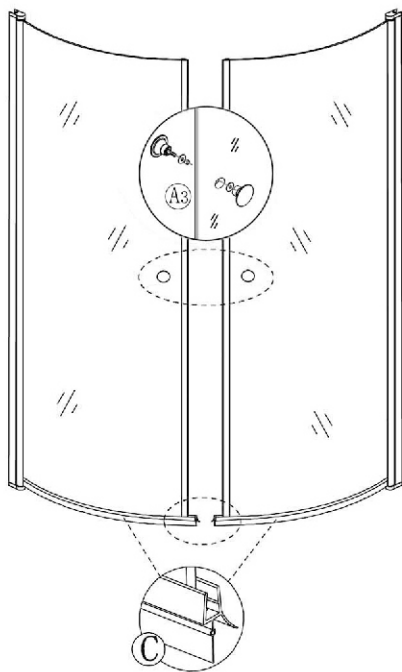

Husk! Være forsiktig med glasset!
Tips: Bruk kil eller lignende for å holde glasset
opp fra gulv

